



## 1. APPLICATION

- A. Metal enclosed, manually operated deadfront padmounted switchgear with load interrupting switches are installed outdoors on pads in EWEB's 12.47 kV grounded y/7.2 kV electric distribution system.

## 2. REFERENCE STANDARDS

- A. The padmounted switchgear shall be manufactured, tested and furnished according to the latest edition, revision or amendments to the applicable standards of ANSI, IEEE and NEMA, including IEEE C37.20.1 through C37.20.7, IEEE C57.12.28 and IEEE C.37.74, except as modified herein.

## 3. PRODUCTS

### A. General Requirements

- 1) The padmounted switchgear shall consist of a single self-supporting metal enclosure containing air break switches, fuses, and insulated busses with necessary accessory components all completely assembled, tested and operationally checked.
- 2) Different models of padmounted switchgear are presented in the standard detail included as a supplement to this specification. The padmounted switchgear model will be specified by EWEB's request for quotation or purchase order.
- 3) The dimensions of padmounted switchgear shall not exceed 75" in width and 73" in depth.
- 4) The unit is to be used on a solidly grounded wye system.

<b>MATERIAL SPECIFICATION</b>			
EUGENE WATER & ELECTRIC BOARD			
		Nov 4, 2014	<b>REV.</b>
<b>DEADFRONT PADMOUNTED SWITCHGEAR – 15KV</b>		<b>ES5-5.1100</b>	<b>0</b>
ENGINEERING REVIEW <u>JDO</u>	STANDARDS COMMITTEE APPROVAL	<u>LMW</u>	Page 1 of 12

## B. Ratings

- 1) The ratings of padmounted switchgear shall be:
  - a) kV, Nominal 14.4
  - b) kV, Maximum 17.0
  - c) kV, BIL 95.0
  - d) Main Bus Continuous, Amperes 600
  - e) Three-Pole Interrupter Switches:  
Continuous, Amperes 600
  - f) Load Dropping, Amperes 600
  - g) Two-Time Duty Cycle Fault-Closing  
Amperes, RMS Asymmetrical 22,400
  - h) Fuses Maximum, Amperes 200E
  - i) Short-Circuit Ratings:  
Amperes, RMS Symmetrical 12,500
- 2) The ratings of switches, bus and fuses shall equal or exceed the ratings of padmounted switchgear.

## C. Construction

- 1) Insulators
  - a) The interrupter-switch and fuse mounting insulators shall be of a cycloaliphatic epoxy resin system or porcelain.
- 2) Bus
  - a) Bus and interconnections shall consist of copper or aluminum bar.
  - b) Bus and interconnections shall withstand the stress associated with short circuit currents exceeding the rating of the switchgear.
  - c) Bolted aluminum-to-aluminum connections shall be made with two Belleville spring washers per bolt, one under the bolt head and one under the nut. Bolts shall be tightened to appropriate torque to assure good electrical connection.
  - d) All electrical contact surfaces shall have aluminum oxide film removed and be immediately coated with an oxide inhibitor and sealant before installation of the bus.

<b>MATERIAL SPECIFICATION</b> EUGENE WATER & ELECTRIC BOARD		
<b>DEADFRONT PADMOUNTED SWITCHGEAR – 15KV</b>	Nov 4, 2014	<b>REV.</b>
	<b>ES5-5.1100</b>	<b>0</b>
Page 2 of 12		

- e) Tie bus, where furnished, shall consist of continuous, one piece sections of copper or aluminum bar. Flexible braid or cable shall not be used.

3) Grounding Provisions

- a) A ground connection pad shall be provided in each termination compartment.
- b) The ground connection pad shall be constructed of 1/4" thick galvanized or nickel plated steel and be welded to the enclosure and shall have a short-circuit rating equal to that of the switchgear and have a NEMA 2 hole pattern for ground connections.
- c) A copper rod having a short-circuit rating equal to that of the padmounted switchgear, shall be provided in each termination compartment. The rod shall extend across the full width of each compartment, readily accessible in an up-front location to allow grounding of cable concentric neutrals and accessories.

4) Bushing and Bushing Wells

- a) Bushing and bushing wells shall be of a cycloaliphatic epoxy resin system and conform to the latest revision of IEEE Standard 386.
- b) The bushing and bushing wells shall be mounted on the interior walls at a minimum height of 30" above the enclosure base.
- c) The semiconductive coating on bushings and bushing wells shall be solidly grounded to the enclosure.
- d) Switch terminals shall be equipped with 600-ampere-rated bushings and shall have removable threaded studs compatible with all 600-ampere elbow systems.
- e) Fuse terminals shall be equipped with 200-ampere-rated bushing wells with removable studs and factory installed 200 ampere load break bushing well inserts, Elastimold catalog #1601A4, or equal.

5) Termination Compartments

<b>MATERIAL SPECIFICATION</b>			
EUGENE WATER & ELECTRIC BOARD			
	Nov 4, 2014	<b>REV.</b>	
<b>DEADFRONT PADMOUNTED SWITCHGEAR – 15KV</b>	<b>ES5-5.1100</b>	<b>0</b>	
Page 3 of 12			

- a) All termination compartments shall be provided with one parking stand for each bushing or bushing well.
- b) Switch Termination Compartment
  - i. Switch termination compartment shall be equipped with a viewing window to allow visual inspection of open gap between interrupter-switch blades when switch is in the open position.
  - ii. Termination compartments for bushings rated 600 amperes continuous shall be of an adequate depth to accommodate two 600 ampere elbows mounted piggyback, encapsulated surge arresters or grounding elbows mounted on 600 ampere elbows having 200 ampere interface, or other similar accessory combinations without the need for an enclosure extension.
- c) Fuse Termination Compartment
  - i. Fuse termination compartment shall be equipped with a set of viewing windows to allow visual inspection of blown-fuse indicator on power fuses.
  - ii. Provide a cable guide for each cable at the base of the enclosure to allow unobstructed rotation of fuse mounting panel. Cable guide shall be a minimum of 8” long from edge of enclosure to inside surface of cable guide.

6) Interrupter Switches

- a) Interrupter switches shall be operated by means of an externally accessible switch-operating hub. The switch-operating hub shall be located within a recessed pocket mounted on the side of the padmounted enclosure and shall accommodate a deep socket wrench or a shallow-socket wrench with extension. The switch-operating hub pocket shall include a padlockable access cover that shall incorporate a hood to protect the padlock shackle from tampering. Stops shall be provided on the switch-operating hub to prevent overtravel and guard against damage to the interrupter switch quick-make quick-break mechanism. Labels to indicate switch position shall be provided in the switch-operating hub pocket.

<b>MATERIAL SPECIFICATION</b>			
EUGENE WATER & ELECTRIC BOARD			
	Nov 4, 2014	<b>REV.</b>	
<b>DEADFRONT PADMOUNTED SWITCHGEAR – 15KV</b>	<b>ES5-5.1100</b>	<b>0</b>	

- b) Each interrupter switch shall be provided with a switch-operating handle which shall be secured to the inside of the switch operating hub pocket and stored behind the closed switch-operating-hub access door.
- c) Interrupter switches shall utilize a quick-make quick-break mechanism installed by the switch manufacturer. It shall swiftly and positively open and close the interrupter switch independent of the switch-operating hub speed.
- d) Each interrupter switch shall be completely assembled and adjusted by the switch manufacturer on a rigid mounting frame. The frame shall be of heavy gauge steel construction.
- e) Interrupter switch contacts shall provide constant high contact pressure.
- f) Interrupter switches shall be provided with a single blade per phase for circuit closing, including fault closing, continuous current carrying, and circuit interrupting. Spring loaded auxiliary blades shall not be permitted.
- g) Circuit interruption shall be accomplished by use of an interrupter which is positively and inherently sequenced with the blade position. It shall not be possible for the blade and interrupter to get out of sequence. Circuit interruption shall take place completely within interrupter, with no external arc or flame.

7) Power Fuse Mounting

- a) Fuse mountings shall accept S & C type SML-20 fuse end fittings and S & C type SMU-20 fuses. Fuse end fittings and fuses are not to be supplied with switch.
- b) Fuse mounting shall be enclosed in an inner steel compartment and shall be provided with 200 ampere-rated bushing wells for elbow connection.
- c) Each fuse mounting shall be an integral part of fuse handling mechanism that does not allow access to the fuse until the elbow for that fuse has been disconnected.

<b>MATERIAL SPECIFICATION</b>			
EUGENE WATER & ELECTRIC BOARD			
	Nov 4, 2014	<b>REV.</b>	
<b>DEADFRONT PADMOUNTED SWITCHGEAR – 15KV</b>	<b>ES5-5.1100</b>	<b>0</b>	
Page 5 of 12			

- d) The opening into the component compartment shall be covered by a panel in both the open and closed position to prevent inadvertent access to high voltage.
- e) Provide fuse retainer bail to secure pull-ring end of fuse assembly to fuse mounting clip.

8) Enclosure

- a) The padmounted enclosure shall be of unitized construction to maximize strength, minimize weight, and inhibit corrosion.
- b) The enclosure and doors shall be minimum 11-gauge hot rolled, pickled and oiled steel sheet.
- c) The enclosure roof shall be diamond shape or have a slope to let the water run off.
- d) All structural joints and butt joints shall be welded, and the external seams shall be ground flush and smooth. A welding process shall be employed that eliminates alkaline residues and minimizes distortion and spatter.
- e) All enclosure corners shall be rounded and finished.
- f) The enclosure shall be provided with tamper-proof ventilation louvers with 300 series stainless steel screens, one near the top and one near the bottom of exterior wall of each termination compartment, to allow circulation of the air.
- g) The enclosure shall guard against unauthorized or inadvertent entry. Enclosure construction shall not utilize any externally accessible hardware.
- h) The base shall consist of continuous 90-degree flanges, turned inward and welded at the corners, for bolting to the concrete pad.
- i) The door openings shall have 90-degree flanges, facing outward, that shall provide strength and rigidity as well as deep overlapping between doors and door openings to guard against water entry.

<b>MATERIAL SPECIFICATION</b>		
EUGENE WATER & ELECTRIC BOARD		
<b>DEADFRONT PADMOUNTED SWITCHGEAR – 15KV</b>	Nov 4, 2014	<b>REV.</b>
	<b>ES5-5.1100</b>	<b>0</b>
Page 6 of 12		

- j) Gasketing between the roof and the enclosure shall guard against entry of water and airborne contaminants and shall discourage tampering or insertion of foreign objects.
- k) A heavy coat of insulating "no-drip" compound shall be applied to the inside surface of the roof to reduce condensation of moisture thereon.
- l) An internal steel-enclosed compartment shall encase the interrupter switches and fuses for electrical insulation and protection from contamination. The compartment shall have a galvanized steel floor to keep out foliage and animals. The floor shall have an additional undercoating to minimize corrosion. The floor shall have screened drain vents to allow drainage if the enclosure is flooded. The top of this compartment shall be gasketed to provide sealing with the enclosure roof.
- m) Insulating interphase and end barriers shall be provided in each switch and fuse compartment. These barriers shall be constructed of fiberglass-reinforced polyester.
- n) Lifting tabs shall be removable and sockets for the lifting tab bolts shall be blind-tapped. A protective material shall be placed between the lifting tabs and the enclosure to prevent the tabs from scratching the enclosure finish. This material shall be non-hygroscopic to prevent moisture from being absorbed.
- o) Doors shall be hinged at the sides to swing open with minimum effort. Each door shall have a door holder which cannot swing inside the enclosure and shall be hidden from the view when the door is closed.
- p) Doors shall have a minimum of three stainless steel hinges and hinge pins. The hinge pins shall be secured in place to guard against tampering.
- q) In consideration of controlled access and tamper resistance, each door (or set of double doors) shall be equipped with an automatic three-point latching mechanism. The latching mechanism shall be spring loaded, and shall latch automatically when the door is closed. All latch points shall latch at the same time to preclude partial latching.

<b>MATERIAL SPECIFICATION</b>		
EUGENE WATER & ELECTRIC BOARD		
<b>DEADFRONT PADMOUNTED SWITCHGEAR – 15KV</b>	Nov 4, 2014	<b>REV.</b>
	<b>ES5-5.1100</b>	<b>0</b>
Page 7 of 12		

- r) A pentahead socket wrench or tool shall be required to actuate the mechanism to unlatch the door and in the same motion, recharge the spring for the next closing operation.
- s) Doors providing access to power fuses shall have provisions to store spare fuse units or refill units.

9) Finish

- a) The padmounted switchgear enclosures shall be coated in accordance with manufacturer's practice, to provide a high quality finish which will not fade, blister or chalk and will be scuff resistant, to ensure a system which is exceptionally serviceable in areas of direct sunlight, high humidity and wide range of temperature.
- b) The manufacturer's coating system shall be tested in accordance with the latest revision of IEEE C.57.12.28 and shall meet or exceed the indicated performance criteria. The tests results shall be made available to EWEB upon request.
- c) Unless otherwise specified, the finish coat shall be manufacturer's standard dark green color.

10) Labeling

- a) NEMA approved warning signs shall be placed on all external doors and inside of each door. All signs shall be applied and located in accordance with latest NEMA standards.
- b) A nameplate indicating the manufacturer's name, catalog number, and model number shall be permanently applied to the inside of at least one door on each padmounted switchgear. Also, the inside of each door shall be provided with a ratings label indicating the following: voltage ratings; main bus continuous rating; short-circuit ratings (amperes, RMS symmetrical and MVA three-phase symmetrical at rated nominal voltage); the type of fuse and its maximum ampere ratings; the interrupter switch ratings, including duty-cycle fault-closing capability and amperes, short-time, RMS (momentary, asymmetrical and one-second, symmetrical).
- c) A three-line connection diagram showing interrupter switches, fuses and bus along with the manufacturer's model number shall

<b>MATERIAL SPECIFICATION</b>			
EUGENE WATER & ELECTRIC BOARD			
	Nov 4, 2014	<b>REV.</b>	
<b>DEADFRONT PADMOUNTED SWITCHGEAR – 15KV</b>	<b>ES5-5.1100</b>	<b>0</b>	
Page 8 of 12			



be provided on the inside of the front and rear doors, and on the inside of each switch-operating-hub access cover.

4. TESTS

- A. Factory Tests: Padmounted switchgear shall be tested according to the latest revision of IEEE C.37.74. The results of testing shall be available to EWEB upon request.

5. WARRANTY

- A. Provide a warranty period of eighteen (18) months minimum after the date of acceptance.
- B. Unless otherwise stated, all equipment shall be free and clear of any lien or encumbrances and shall be new and the current model and shall carry full manufacturer warranties.
- C. Vendor warrants to EWEB that any goods/equipment furnished will operate and function in the manner represented by Vendor and will achieve the performance stated in the material specification when operating within the design conditions described therein.
- D. Vendor warrants the goods/equipment furnished is free from defects in material and workmanship, and agrees to repair or replace any unit that is unsuitable for operating or fails in operation during normal and proper use, including all parts and labor at no cost to EWEB.

6. PACKAGING AND DELIVERY

- A. The vendor shall protect the padmounted switchgear and any exposed parts during transit. Any damage in transit is the vendor's responsibility.

7. SUBMITTALS

- A. Submit the information required in Exhibit A.
- B. Provide one (1) set of drawings and instruction books before shipment of the padmounted switchgear. One complete set of drawings and instruction books

<b>MATERIAL SPECIFICATION</b>		
<b>EUGENE WATER &amp; ELECTRIC BOARD</b>		
<b>DEADFRONT PADMOUNTED SWITCHGEAR – 15KV</b>	Nov 4, 2014	<b>REV.</b>
	<b>ES5-5.1100</b>	<b>0</b>

Page 9 of 12

shall accompany the padmounted switchgear. All instruction books shall be provided in PDF file format and all drawings shall be provided in the latest version of AutoCAD®, or PDF file format.

8. EWEB STORES INFORMATION

A. This specification shall be used to purchase the material with the following stock codes:

492-0001800 Model 9. Deadfront Padmount Switch, 600 Amp, Two 3 Pole Disconnects, Two 200 Amp 3 Pole Fuse Positions.

492-0001802 Model 11. Deadfront Padmount Switch 600 Amp, Three 3 Pole Disconnects, One 200 Amp 3 Pole Fuse Position.

492-0001803 Model 5. Deadfront Padmount Switch 600 Amp, One 3 Pole Disconnect. One 200 Amp 3 Pole Fuse Position.

<b>MATERIAL SPECIFICATION</b>		
EUGENE WATER & ELECTRIC BOARD		
	Nov 4, 2014	REV.
<b>DEADFRONT PADMOUNTED SWITCHGEAR – 15KV</b>	<b>ES5-5.1100</b>	<b>0</b>

Page 10 of 12

Date: \_\_\_\_\_

**EXHIBIT A**

**SPECIFIC INFORMATION REQUIRED WITH BID  
DEADFRONT PADMOUNTED SWITCHGEAR  
(Submit Separate Sheets for Each Bid Item)**

Manufacturer's Name: \_\_\_\_\_

Distributor's Name: \_\_\_\_\_

- 1. PADMOUNTED SWITCHGEAR MODEL \_\_\_\_\_
- 2. VOLTAGE:
  - a. KV, Nominal \_\_\_\_\_
  - b. KV, Maximum design \_\_\_\_\_
  - c. KV, BIL \_\_\_\_\_
- 3. MAIN BUS CONTINUOUS AMPERES \_\_\_\_\_
- 4. INTERRUPTER SWITCHES:
  - a. Continuous Amperes \_\_\_\_\_
  - b. Load Dropping Amperes \_\_\_\_\_
  - c. Two-Time Duty Cycle, Fault Closing \_\_\_\_\_
  - d. RMS Asymmetrical Amperes \_\_\_\_\_
- 5. FUSES, MAXIMUM AMPERES \_\_\_\_\_
- 6. SHORT CIRCUIT RATINGS:
  - a. RMS Symmetrical Amperes \_\_\_\_\_

Submit a drawing of the switch showing the dimensions, vent locations and switch and fuse configuration in accordance with the requirements of the bid documents.

<b>MATERIAL SPECIFICATION</b>		
<b>EUGENE WATER &amp; ELECTRIC BOARD</b>		
	Nov 4, 2014	<b>REV.</b>
<b>DEADFRONT PADMOUNTED SWITCHGEAR – 15KV</b>	<b>ES5-5.1100</b>	<b>0</b>

Page 11 of 12

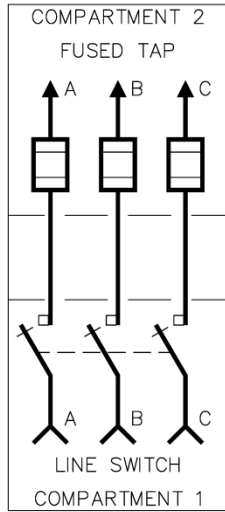

MODEL 5  
 EWEB STOCK CODE 492-0001803

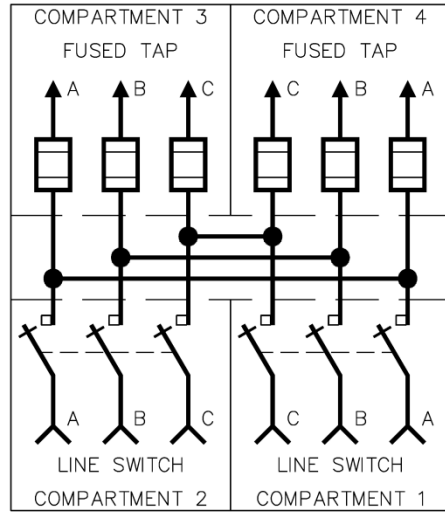

MODEL 9  
 EWEB STOCK CODE 492-0001800

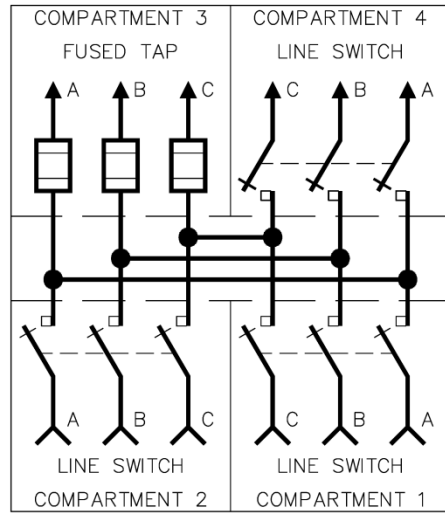

MODEL 11  
 EWEB STOCK CODE 492-0001802

DEADFRONT PADMOUNTED SWITCHGEAR CONNECTION DIAGRAM  
STANDARD DETAIL ES5-5.1100.01

<b>MATERIAL SPECIFICATION</b>		
EUGENE WATER & ELECTRIC BOARD		
<b>DEADFRONT PADMOUNTED SWITCHGEAR – 15KV</b>	Nov 4, 2014	REV.
	<b>ES5-5.1100</b>	<b>0</b>
Page 12 of 12		